



SEE SOLUTIONS



tampondruck padprinting

ITW  **MORLOCK**
TAMPONDRUCK - SYSTEME

MKM

The best solution for multi-colour pad printing.

This machine type with its special characteristics is truly unique in the pad printing world. The MKM 125.3 and MKM 80.3 have convinced customers for many years through reliability, versatility and precision. This MKM concept unites complex precision technology with amazingly simple handling and offers a variety of application usages.

Maximum image:

MKM 80.3:

Ø 55 mm or 40x40 mm

MKM 125.3:

Ø 105 mm or 70x70 mm



80.3 125.3
MKM
DIE EXCLUSIVE



- Four-colour or five-colour machine
- Electro-mechanical drive
- Fully mechanical machine
- Compact, robust design
- Continuous pad cleaning while printing without time delay
- Minimum setup time due to easy adjustment
- optional: version with multipositioning system
- Highest print quality with exact repeatability
- Exceptionally quiet operation
- Single fixture reduces tool cost
- Closed ink cup system MCI

MTE QUICK

Pad printing with an added dimension.

The MTE does not limit printing within 2 dimensions of an image. This machine type also enables printing on two different levels through individually adjustable pad stroke heights.

MORLOCK now offers the MTE Quick with a high-speed variation of this design.

Print image sizes:

Ink cup options: round or oval

MTE Quick 1.0:

to Ø 105mm or 110x45mm

MTE 125 LS:

to Ø 105mm or 300mm long



125LS 1.0 QUICK MTE

DIE INNOVATIVE



- One-colour or two-colour machine
- flexible cliché sizes
- various adjustable printing levels
- 2 individually controlled printheads
- high printing precision
- high repeatability and accuracy
- simple handling and good accessibility

- compact design
- small space requirement
- pad stroke and ink cup pneumatically driven
- pendulum movements electrically driven
- closed ink cup system MCI
- MTE Quick: approx. 1.400 cycles/h in two colour mode; in single colour mode slightly higher speed



MM 6

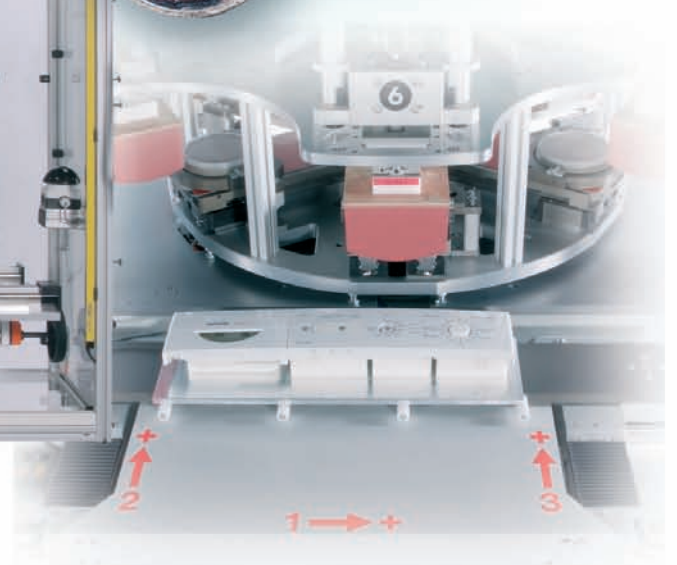
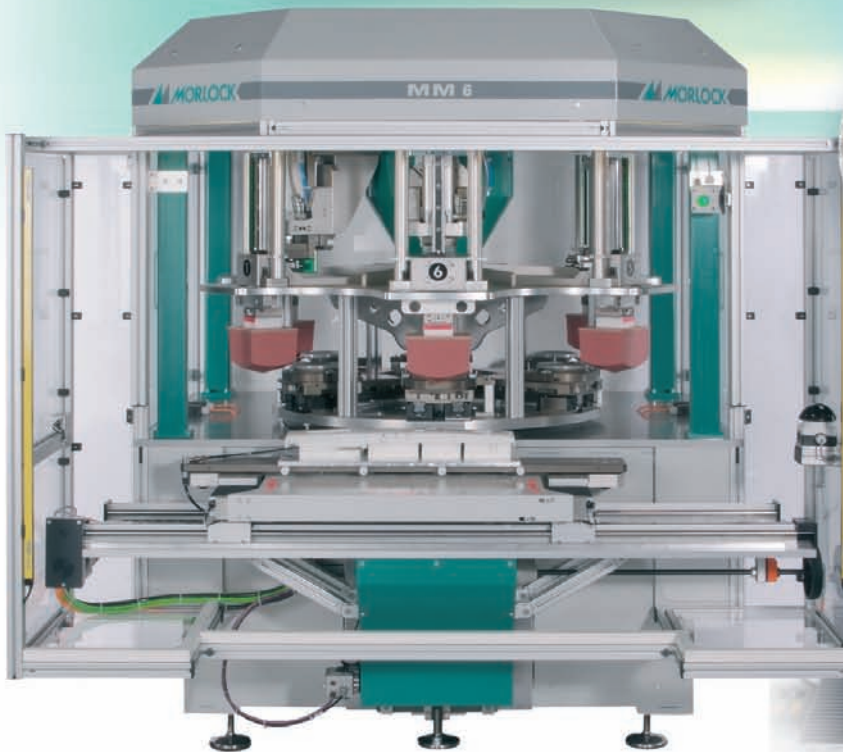

As unique as our customers are, so are their requirements.

Whatever the individual technical requirements are, together with the customer we will find the best economical solution.

Special machines, automations and semi-automations have been the strength of MORLOCK for many years.

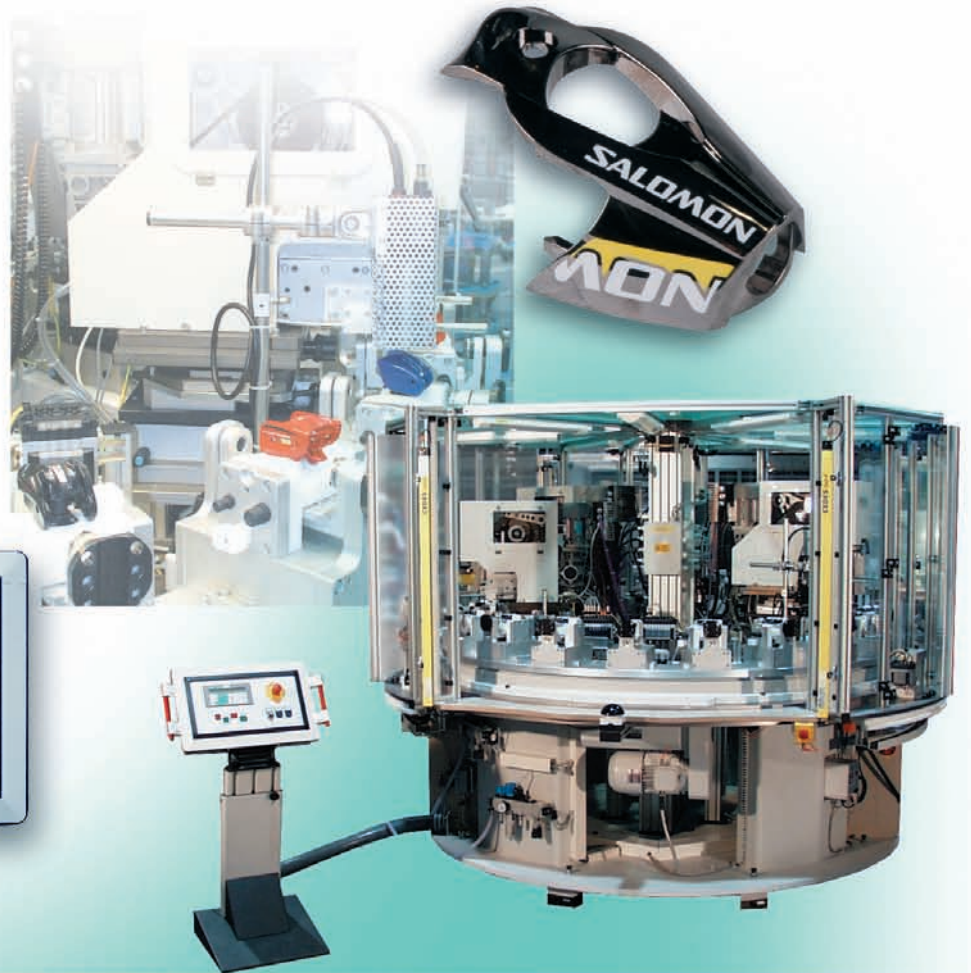
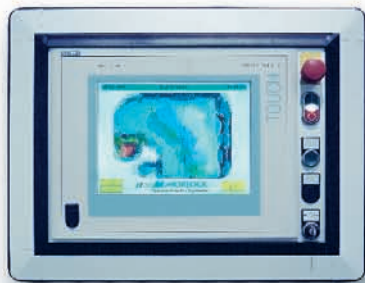

SPEZIALMASCHINEN

DIE INDIVIDUELLE LÖSUNG

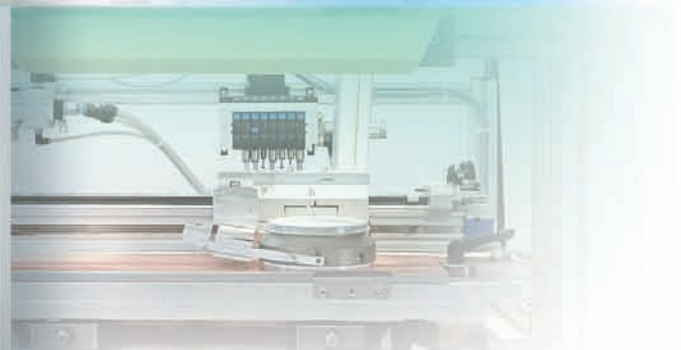

- customer specific, individual solutions
- automations / semi-automations built in-house
- specific designs
- complete solutions
project review – planning
design – manufacturing
assembly – production start / service

- many versions
- optimal design for integration in automation lines
- optional pad cleaning
- closed ink system MCI and oval
- Swiveling version round and oval



MDX

One type – many versions.

The MDX product line is based on a base model. The compact and space-saving design allows for easy integration into automation lines.

Print image sizes:

Up to Ø 105 mm or 160x80 mm
Flexible and versatile
programmation handling

MDX

THE VERSATILE TYPE

PRINTING POSITIONS

Standard

Pad in ink taking position
extended cliché

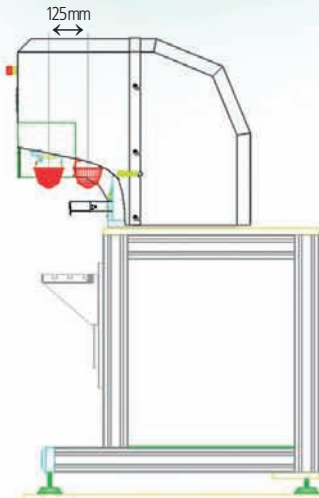

Option print head movement

Printing in hollow
behind interference edge

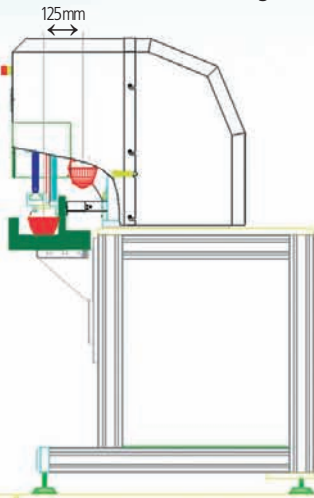

Printing in hollow

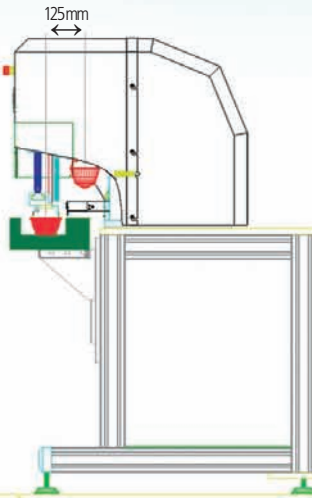

Printing over cliché niveau
„upstairs“

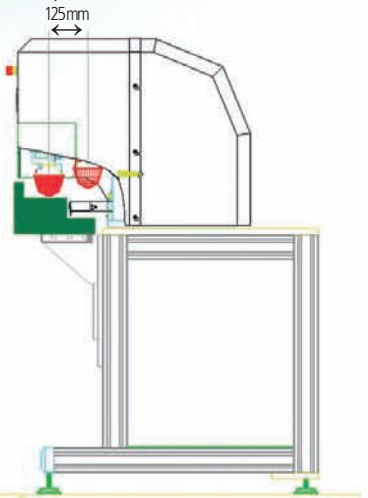



... ALLES AUS EINER HAND

DAS ZUBEHÖR



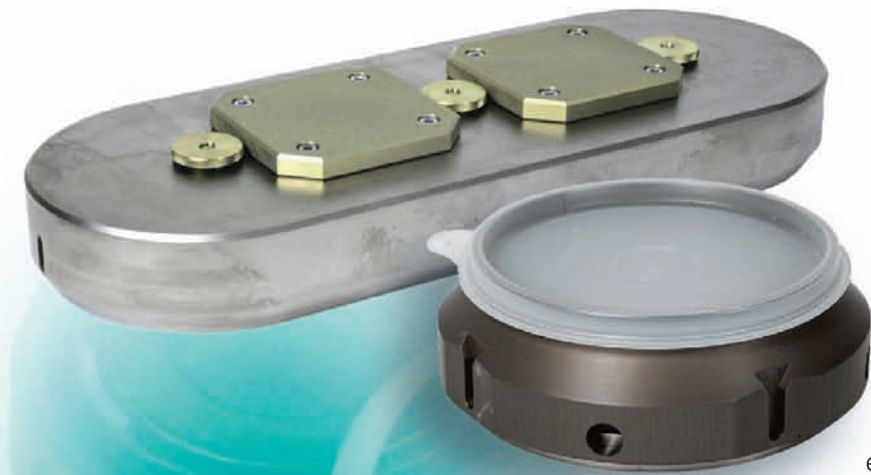

ACCESSORIES

Reliable quality – single source.
There is nothing more environmentally safe and convenient!

We offer a full selection of machine components and consumables according to your requirements. This makes pad printing simple, consistent and efficient!

Our own state of the art production and processing systems for ink, cliché, and pad production guarantee our customers the highest quality standards for accessories.

We ensure a lasting and reliable maintenance of these standards through ongoing quality control and continuous testing of new products.

But even the small and large “helpers” needed during the pad printing process can be found at MORLOCK. And if you are not sure or have any special requests, you are welcome to contact our Service-Team.

The MORLOCK complete product line for pad printing accessories can be found either in the catalogue or on our website www.itwmorlock.com

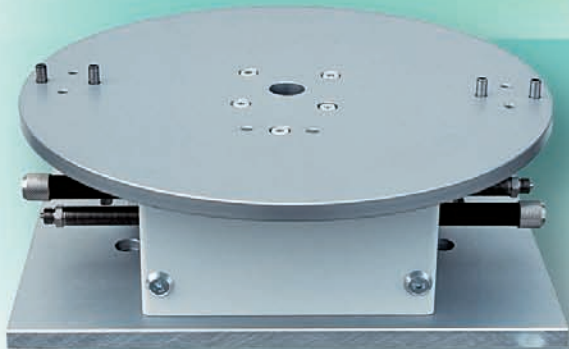
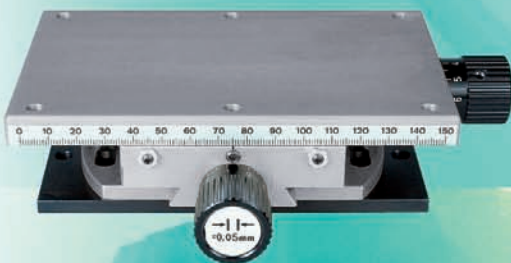

MSC

High-speed pad printing.

This mechanical machine type stands out with its high-speed and excellent integration ability.

Print image size:
Ø 80 mm



- mechanical and reliable high speed machine
- high precision
- suited for automations
- integration machine
- flexible solutions
- closed ink cup system MCI



MSC
DIE SCHNELLE



MDM
DIE MODULARE

- integration module
- various ink cup and print size
- can be controlled through external control module
- optional pad cleaning
- integrated X-Y-R – adjustment



MDM

The integration solution.

The MDM machine can be configured individually based on print image size and ink cup. As a modular unit it can also be integrated in automation lines.

Print image sizes:
to Ø 170mm or 120x120mm

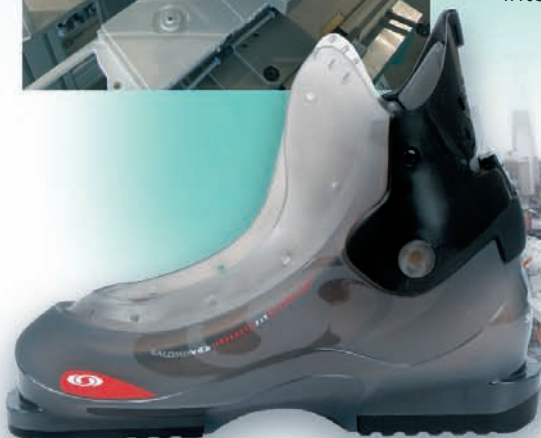

ITW Morlock GmbH
An ITW Decorating Company

Lise-Meitner-Straße 9
D-72280 Dornstetten
Germany

fon +49(7443)285-0
fax +49(7443)285299

info@morlock.de
www.morlock.de

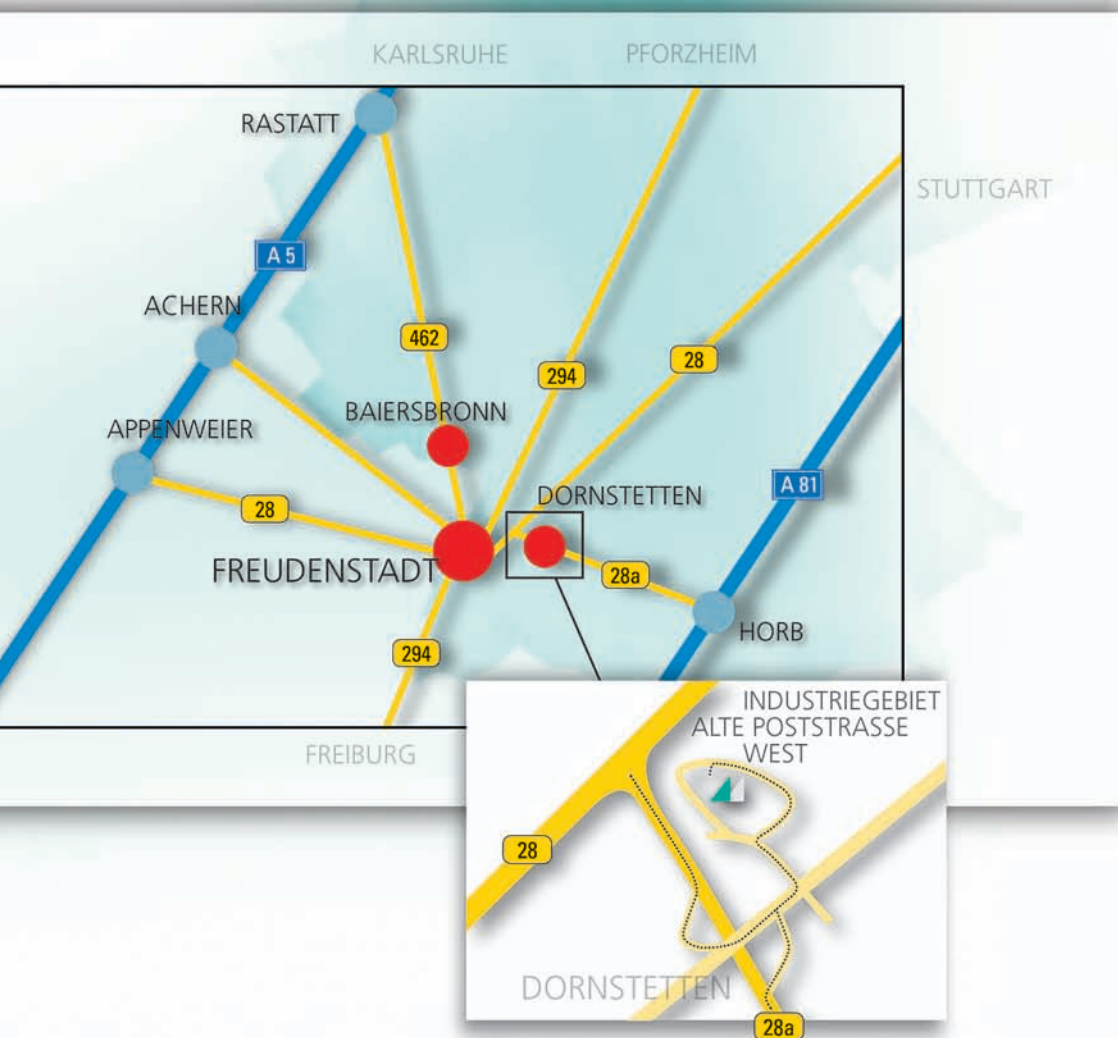

How to get to ITW Morlock

From A 5 Highway/Autobahn (Frankfurt-Basel)

Exits Rastatt - Achern - Appenweier

From A 81 Highway/Autobahn

(Stuttgart - Singen) Exit Horb

either one - direction **Freudenstadt**